

**The Book of the**



**SUPER  
LAWN MOWER**









## FOREWORD

IN the Patented J.P. SUPER LAWN MOWER neither effort nor expense has been spared to produce the **Best Possible Machine**, as regards design, material, accuracy of workmanship and finish, and one incorporating every known desirable feature :—

A MASTERPIECE  
IN HIGH-CLASS  
ENGINEERING.

Use this machine as you would a high-grade bicycle. With proper care it will last a lifetime. What is more, attention to these instructions will repay you by added ease of working.



**THE J.P. ENGINEERING CO. LIMITED**

*Manufacturers of J.P. Super Lawn Mowers*

**MEYNELL ROAD, LEICESTER, Eng.**

Telegrams :  
"SUPERLAMO, LEICESTER"

Telephone :  
LEICESTER 67542 (2 lines)



**THE SUPER J.P. LAWN MOWER**

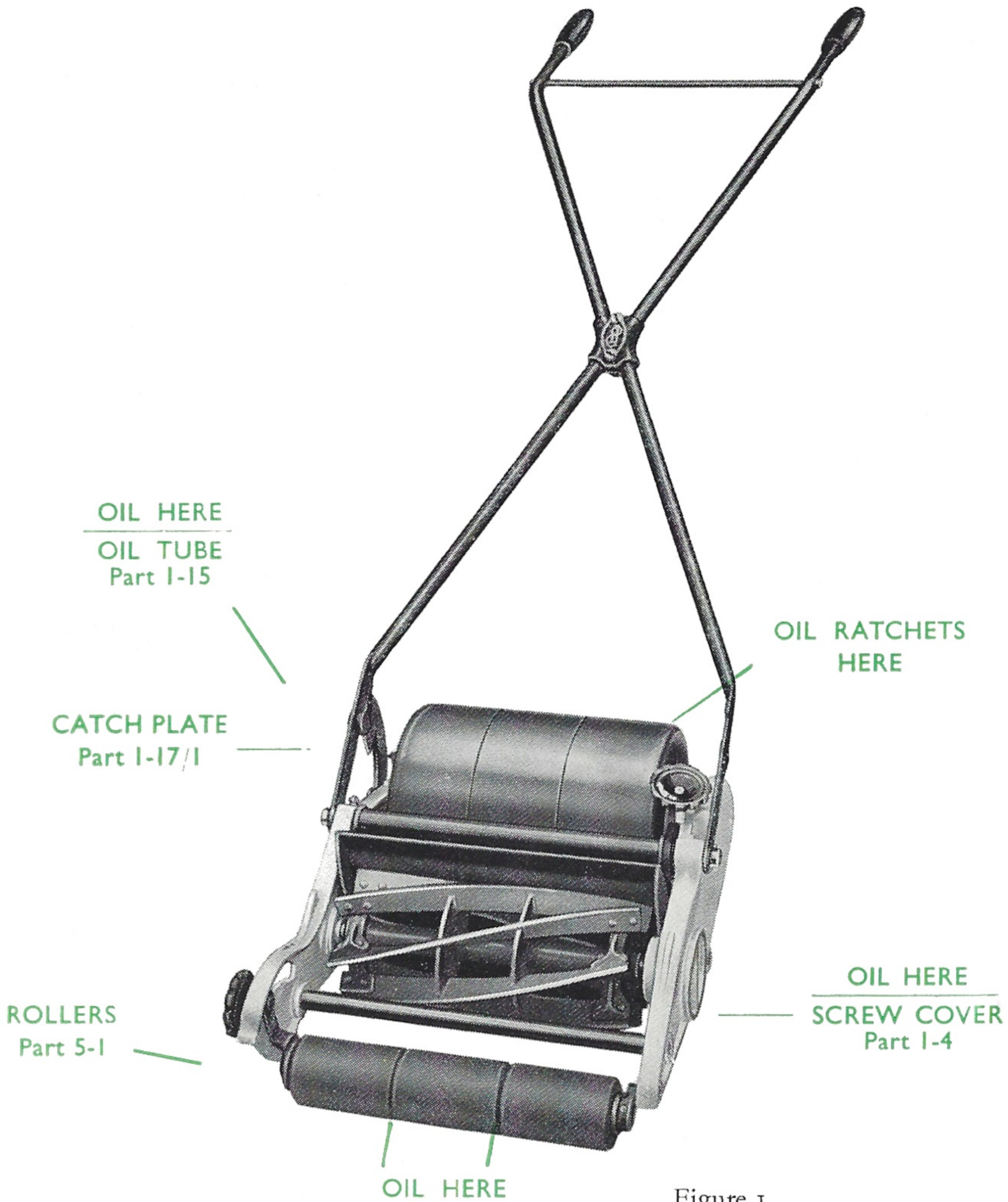

Figure 1

**I.—RAISING THE HANDLES**

The working height of the handles is adjustable to three positions by the catch plate 1-17/1 (see Fig. 1). Unscrew the knurled nut on the projecting end of rear axle shaft 2-16. The handles can then be positioned and the knurled nut engaging in one of the three notches in the slot of the catch plate should be screwed up tight.



# **THE SUPER J.P. LAWN MOWER**

## **2.—OILING THE CHAIN (Every three months)**

Remove all TRACES OF GRIT and place the machine on a sheet of paper. With the machine is sent a special box spanner having slots in the end by means of which the screw cover 1-4 (see Fig. 1) can be removed. Tip the machine back to raise the front rollers and oil the chain with a little good *light* lubricating oil ; replace the cover and screw it up tightly to prevent leakage.

Avoid using thick oils or greases with the J.P. Super.

## **3.—OILING THE BACK ROLLER (Every three months)**

The centre portion of the back roller contains a nest of gear wheels (which increase the speed of the rotary cutter) running in an oil bath, charged before delivery. This oil will be kept up to its level by periodically filling tube 1-15 (Fig. 1) nearly to the top. Take care to close the flap afterwards to prevent the entrance of dirt. Oil the ratchets through the two holes in ends of roller, pushing in the brass sealers with the end of the oil can nozzle.

## **4.—OILING THE FRONT AXLE (Frequently)**

- (a) On the standard type the hard wood front rollers should be well lubricated with J.P. or similar thin machine oil. Apply oil on the shaft at the space between the rollers. To facilitate the oil feed tip machine on each side. Frequent attention will prevent chattering noise.
- (b) Where light alloy metal front rollers are fitted as special these are provided with self-lubricating bearings and a supplementary oil reservoir.



# THE SUPER J.P. LAWN MOWER

- (c) For cleaning, etc., the axle may be removed by unscrewing from the aluminium side frames the two supporting studs, having first removed the Split Pin, Screwed Handwheel and Spring Washer.

IMPORTANT :—Use J.P. Oil, obtainable in Pint Tins from all Stockists, or from us direct, in case of difficulty.

## 5.—ATTENTION TO BALL BEARINGS (Annually)

The ball bearings, which can be seen when the screw cover 1-13 is removed, should be packed with clean vaseline once a year. First remove all traces of *dirt* or *grit* and place machine on a clean sheet of paper, wash your hands and *take care that no trace of dirt gets into the oil or bearings.*

NOTE :—The slightest trace of *grit will ruin in a few weeks* ball bearings that should last for years.

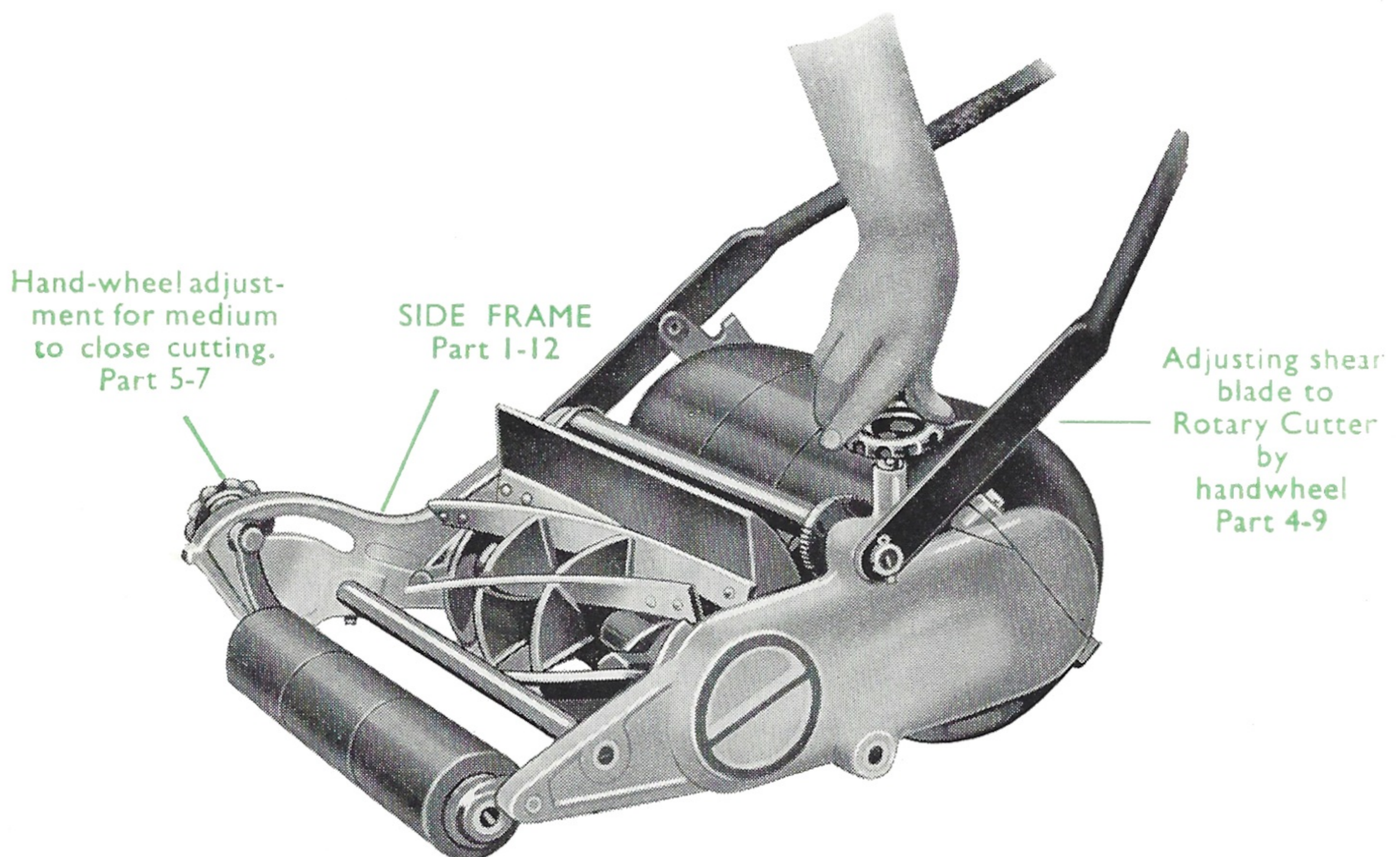

Figure 2



# **THE SUPER J.P. LAWN MOWER**

## **6.—SETTING THE ROTARY CUTTER TO THE SHEAR BLADE**

The rotary cutter works against a bottom shear blade and the latter is adjusted and brought into contact with the rotary cutter by turning the handwheel 4-9 (Fig. 2) in the direction of arrow.

Turn the handwheel *just sufficient until a light audible contact is heard* as the cutter is spun round.

In spinning the cutter keep the hand at the top of machine away from the shear blade otherwise the fingers may be caught and badly cut.

*Do not turn handwheel too far* as this will only make a harsh contact thereby increasing the wear on the blades, making the machine hard to push, and produce no better cutting results.

## **7.—ADJUSTING FOR CLOSE TO MEDIUM CUTTING**

The adjustment for length the grass is to be cut to is made by handwheel 5-7 (see Fig. 2). The illustration shows the machine set for cutting a heavy crop. This does not mean a hay field, extra long grass must be cut with a scythe before using the lawn mower. This handwheel 5-7, should not be set too far back when going over the lawns for the first time in the season, keep it well in front of the arrow mark, which is above the slot on the side frame 1-12. As the ground gets hard and firm the lever can be set further back until the machine will be set so low that it will practically shave the lawn. This is ideal for bowling greens and tennis courts, but unless the ground is very level and hard the lever should not be set below the arrow mark.

After moving the handwheel be careful to re-tighten it firmly to prevent the adjustment shifting.



# THE SUPER J.P. LAWN MOWER

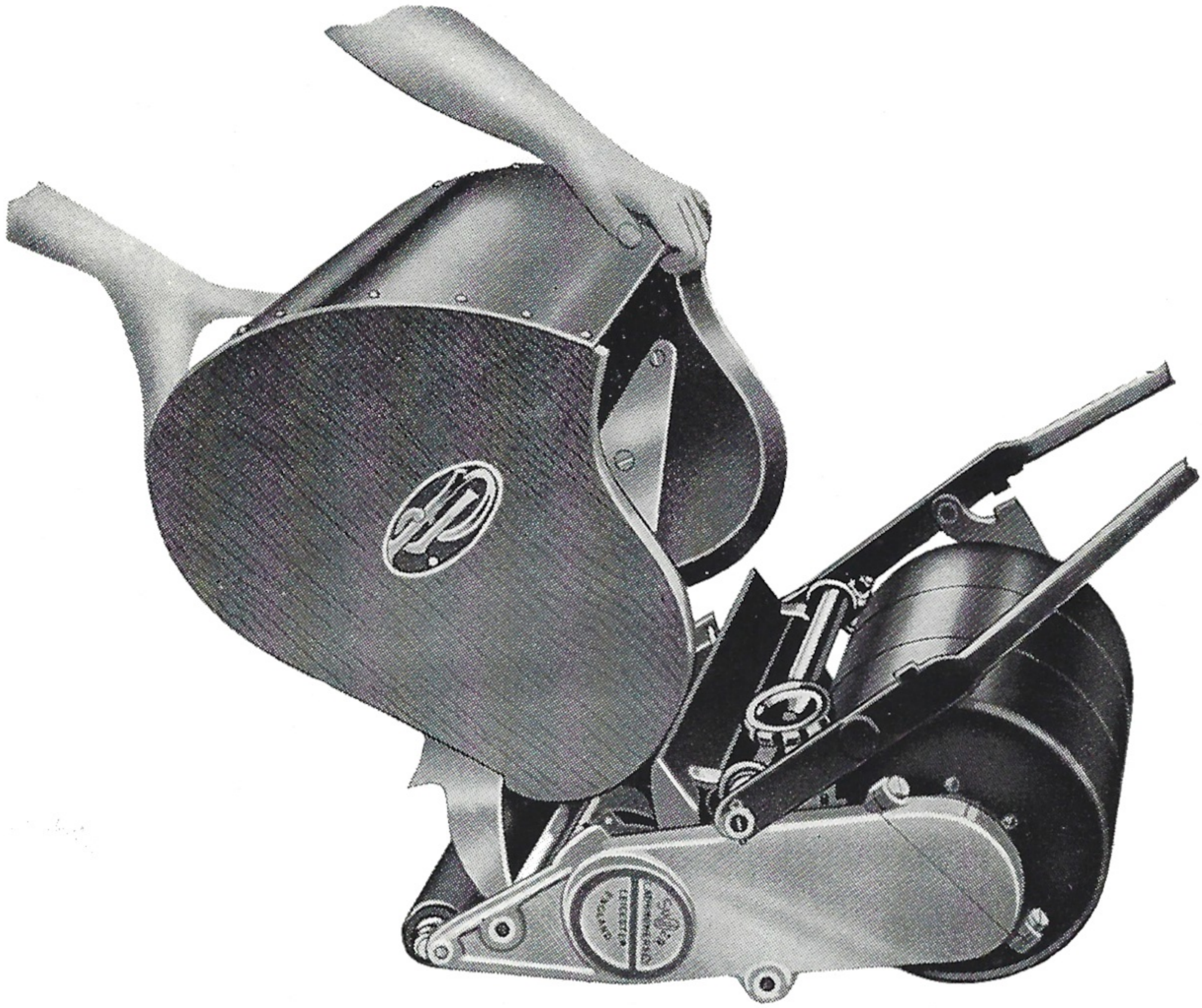

Figure 3

## 8.—HANDLING GRASS BOX

The fitting on of the grass box is shown in Fig 3. The notches in the two metal wings, 6-6, 6-7, of the grass box fit on the cross rod 1-7, that lies between the front rollers and the cutter, and the toes of the wings fit under the frame bosses. See that the box is well down on the rod or it may foul the cutter, which is a bad thing for both.

If the machine is adjusted as before described, work should proceed with gratifying results as to speed and ease of operation and provide a new experience in the use of lawn mowers.



# THE SUPER J.P. LAWN MOWER



Figure 4

## 9.—STORING AND CARE OF MACHINE

Upon completion of the mowing, clean off clinging grass or dirt, then store machine in a *dry* tool shed. Unscrew the knurled nut on the rear axle shaft, the handles can then be lowered. Screw up and engage the knurled nut in the bottom notch of the catch plate, the machine can then be raised bodily into the position shown in Fig. 4, taking a minimum of space behind the door or against the wall. This will keep cutters and bearings away from the damp ground and also from possible damage. Wipe the rotary cutter and shear blade with an oily rag. This *should always be done* to prevent rusting and will help to keep the cutters sharp.



# THE SUPER J.P. LAWN MOWER

Greatest care is taken in producing the J.P. Super Lawn Mower, and care to follow these instructions in using it will not only pay but show the efficient workman.

## 10.—REMOVING THE ROTARY CUTTER FOR SHARPENING

If proper care is taken to adjust, oil and clean the cutters as in the preceding paragraphs, the rotary cutter should work for two seasons before becoming dull. It is easily removed from the machine for re-sharpening. Illustrations 5 and 6 show how this is done. First *thoroughly* clean machine, removing *all* grit, dust and place on a large sheet of clean paper, unscrew the small screw cover I-13 (see Fig. 4), then remove the large screw cover I-4.

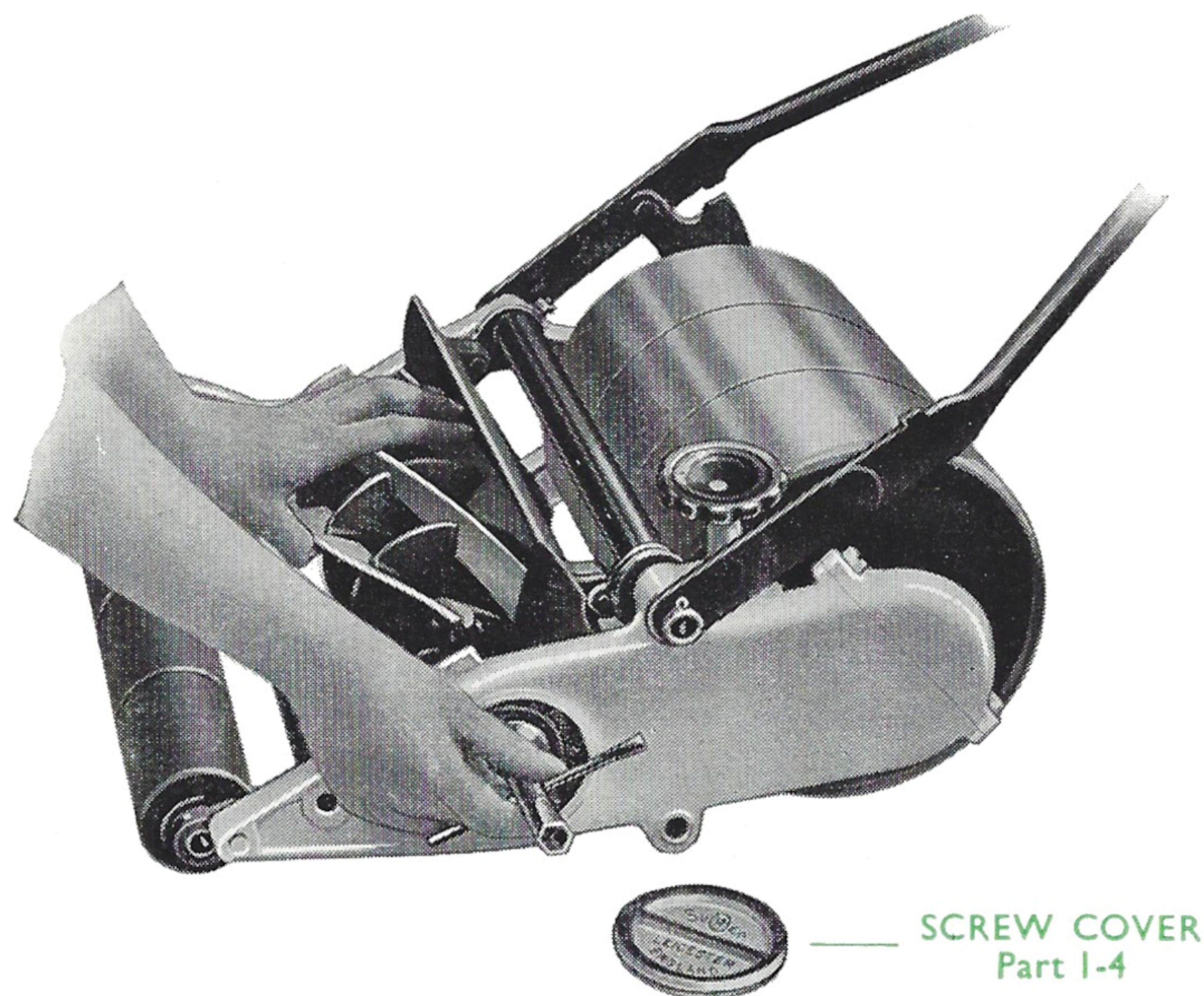

Figure 5



# THE SUPER J. P. LAWN MOWER

In the recess in the chain wheel there will be seen a small nut 3-3, unscrew this two turns with the box spanner supplied with kit (this is being done in Fig. 5), then tap the end of the spanner lightly with a block of wood to loosen the shaft 3-2 ; remove the nut and with the spanner handle push the shaft inwards until the opposite end can be grasped with the left hand. Holding the cutter with the right hand, the shaft may now be drawn completely out of the machine, and the rotary cutter simply lifted from the frames as shown in Fig. 6. Replace the shaft and nut and the caps in the machine to prevent dust getting in, and, if need be, oil the shaft to prevent it rusting.

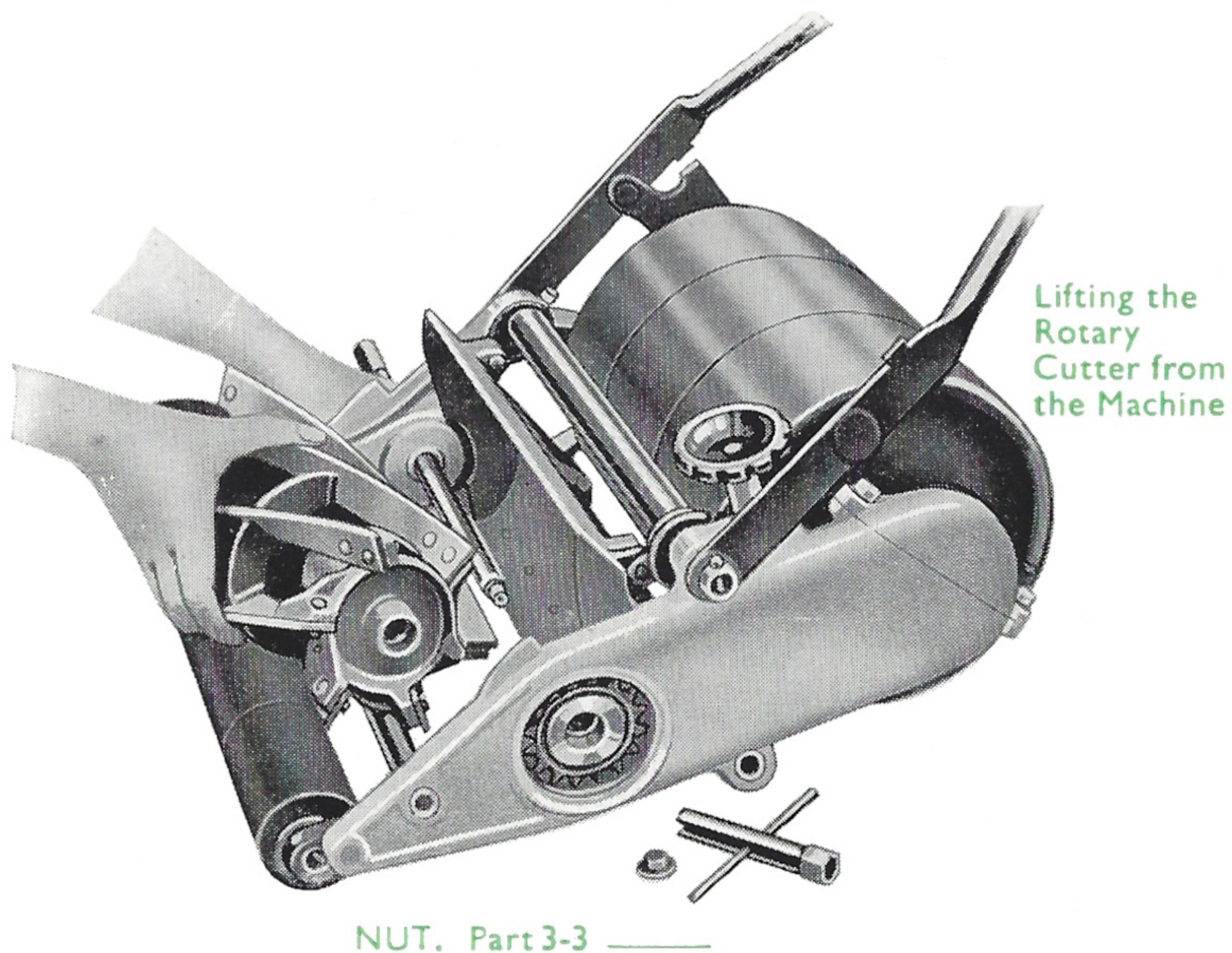

Figure 6



# **THE SUPER J. P. LAWN MOWER**

## **11.—REPLACING THE ROTARY CUTTER**

Before putting the cutter back, examine the ends and carefully remove *all* trace of dirt and grit. It will be found that one end has three keys formed in it. Place this end over the projecting cone of the sprocket wheel sleeve 3-4 (Plate 3), which may be seen on the chain gear box side and will be recognised by three keys similar to those in the cutter. Insert the shaft 3-2 from the other side of the machine, turning it to bring its grooves opposite the keys in the cutter and sprocket wheel sleeve (a mark is provided on the edge of the hub of the rotary cutter to correspond with similar marks on the projection cone of the sprocket wheel sleeve to facilitate this), then push it firmly home, replace the shaft nut and screw up tight. Oil the chain (par. 2) and replace screw covers.

*Note the slightest trace of dirt or grit on shaft or in bore of cutter will throw cutter out of true.*

## **12.—REVERSING THE SHEAR BLADE**

When the front edge of shear blade is worn, it should be reversed to the opposite edge. To do this, lay the machine on its back and using *wide* screwdriver, take out the shear blade screws. Then lift the blade off the frame face, *clean and oil both faces*, turn blade round with the new edge to the rotary cutter. Insert screws and half tighten, then finally screw up each one hard and tight. Adjust for alignment if necessary to instruction (Parallelism of Cutters—No. 13).

## **13.—PARALLELISM OF CUTTERS**

The mower is set and locked before despatch to cut equally along the whole length of the blades when adjusted as per Section 6, page 5. It should not need further setting unless it has been dismantled or subjected to excessive shocks, or through the rotary cutter fouling an obstruction. To correct any misalignment of the rotary cutter with the shear blade, proceed as follows :—

Turn the machine over or stand it on end, loosen for about two turns the cotter nut that is seen projecting from one end of the bearing of the knife frame 4-3 (see Plate 4-0) ; then tap the cotter inwards to free it. Now slightly rotate the phosphor bronze eccentric bearing in the frame by using a suitable punch



# **THE SUPER J.P. LAWN MOWER**

in the small holes. Rotate in the direction required to bring the bottom blade parallel with the rotary cutter, testing the parallelism of the cutters by cutting with a strip of paper until the knives cut evenly at each end. *Re-lock the frame cotter nut after setting.*

## **After-Service and Instructions for Ordering Spare Parts**

1.—We have available a first class overhaul and repair service department, fully equipped with modern facilities. Consult your dealer with regard to your requirements or, in case of difficulty, contact us direct. Always see that the machines and cutters returned for overhaul and regrinding are properly packed and labelled with the name and address of the sender securely attached. On request, we will despatch a crate for the return of your machine for works overhaul and service attention.

2.—Plates 1 to 6 illustrate lists of parts. Each part is clearly shown and the number and description quoted. Always give part number and description in full.

3.—All machines and component parts must be consigned to us, carriage paid, addressed to the "Service Department"; goods returned by rail are consigned Carriage Paid. Old and worn out parts sent as patterns which we consider are obsolete and of no further use, are not returned unless we are specially requested to do so at the time they are sent to us.

4.—When ordering spare parts always quote the number of the machine which you will find stamped on the front top edge of the chain case side frame. The "Super" model of machine is manufactured in three sizes—12", 14" and 16" cut; it is important that the prefix letters and the serial number reference are quoted in full, in order that the correct parts are despatched.

5.—If required, we are prepared to submit an estimate before proceeding with any repairs. Estimates must be treated as approximate only. We reserve the right to include additional parts should they be found necessary on further examination to make the repair a satisfactory job.

6.—Special thin shear blades are required and fitted to Bowling Green and Golf Green Models only, and these should be referred to as "No. 3 Razor Type."



# PARTS LIST

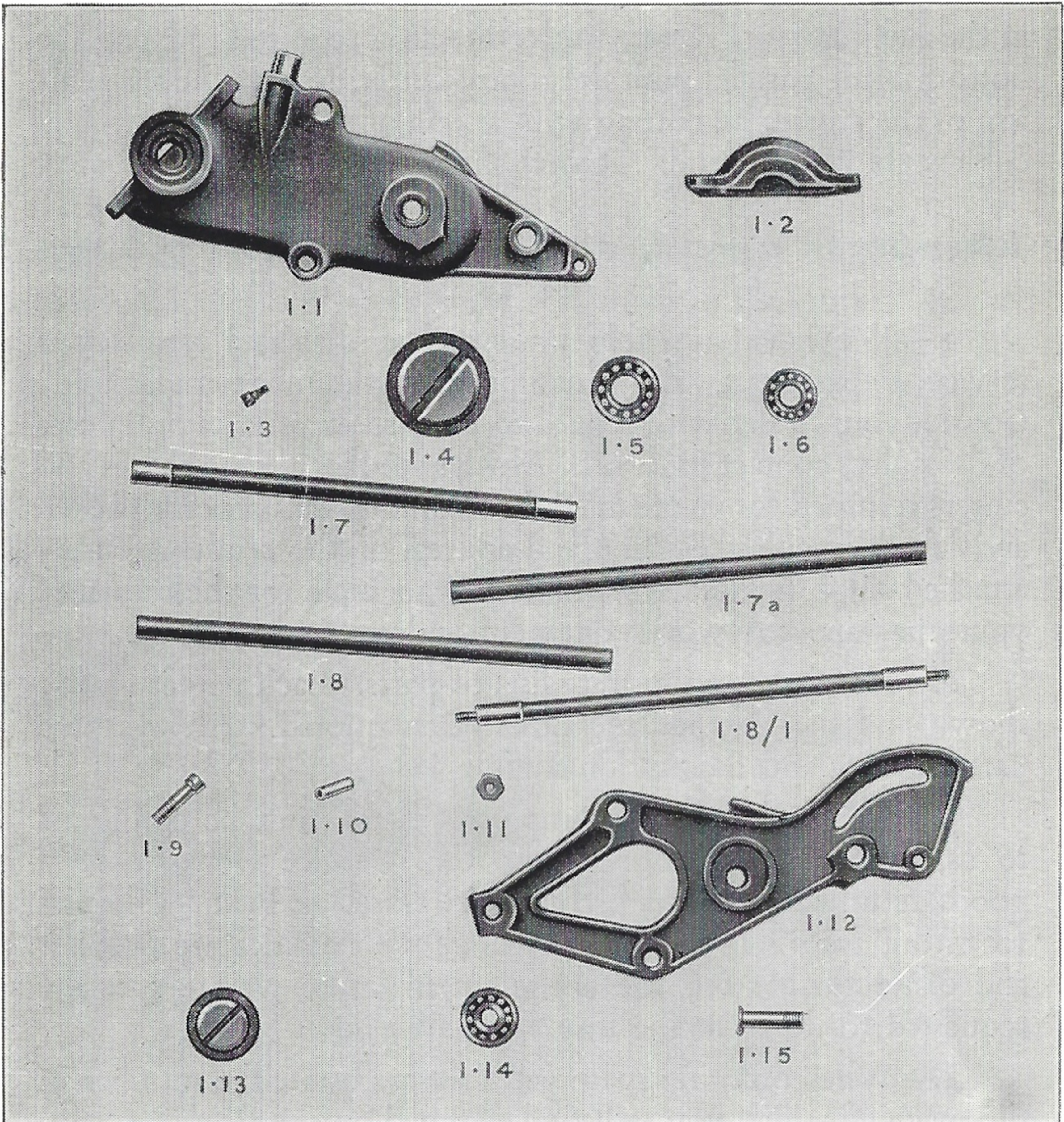

## GROUP 1-0

- |                         |                           |
|-------------------------|---------------------------|
| 1-1—Chain Gear Box      | 1-8A—Split Pin            |
| 1-2—Chain Gear Box Cap  | 1-8/1—Top Tie Bar         |
| 1-3—Cap Screw           | 1-9—Cotters               |
| 1-4—Large Screw Cover   | 1-10—Cotter Sleeves       |
| 1-5—Large Ball Bearing  | 1-11—Cotter Nuts          |
| 1-6—Medium Ball Bearing | 1-12—Removable Side Frame |
| 1-7—Front Cross Tube    | 1-13—Small Screw Cover    |
| 1-7A—Lower Cross Tube   | 1-14—Small Ball Bearing   |
| 1-8—Long Cross Tube     | 1-15—Lubricator           |



## PARTS LIST—continued

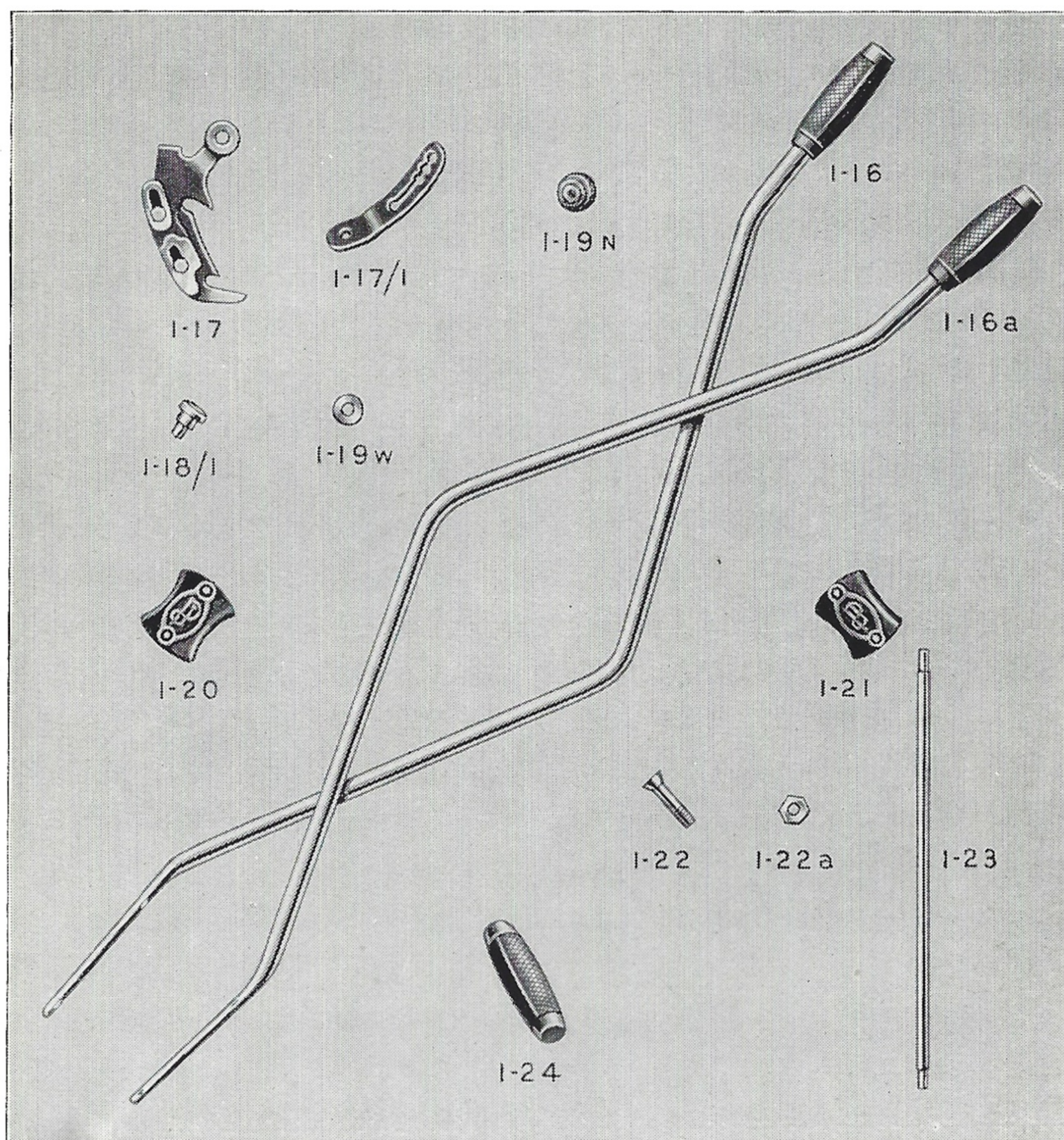

### GROUP 1-0

1-16—Handle R.H. Side Bar  
 1-16A—Handle L.H. Side Bar  
 1-17—Latch Plate  
 1-17/1—Catch Plate  
 1-18/1—Latch Plate Stud  
 1-19N—Knurled Nut  
 1-19W—Latch Washer

1-20—Top Handle-bar Clip  
 1-21—Bottom Handle-bar Clip  
 1-22—Clip Bolts  
 1-22A—Clip Bolt Nuts  
 1-23—Tie Rod  
 1-24—Grips



## PARTS LIST—continued

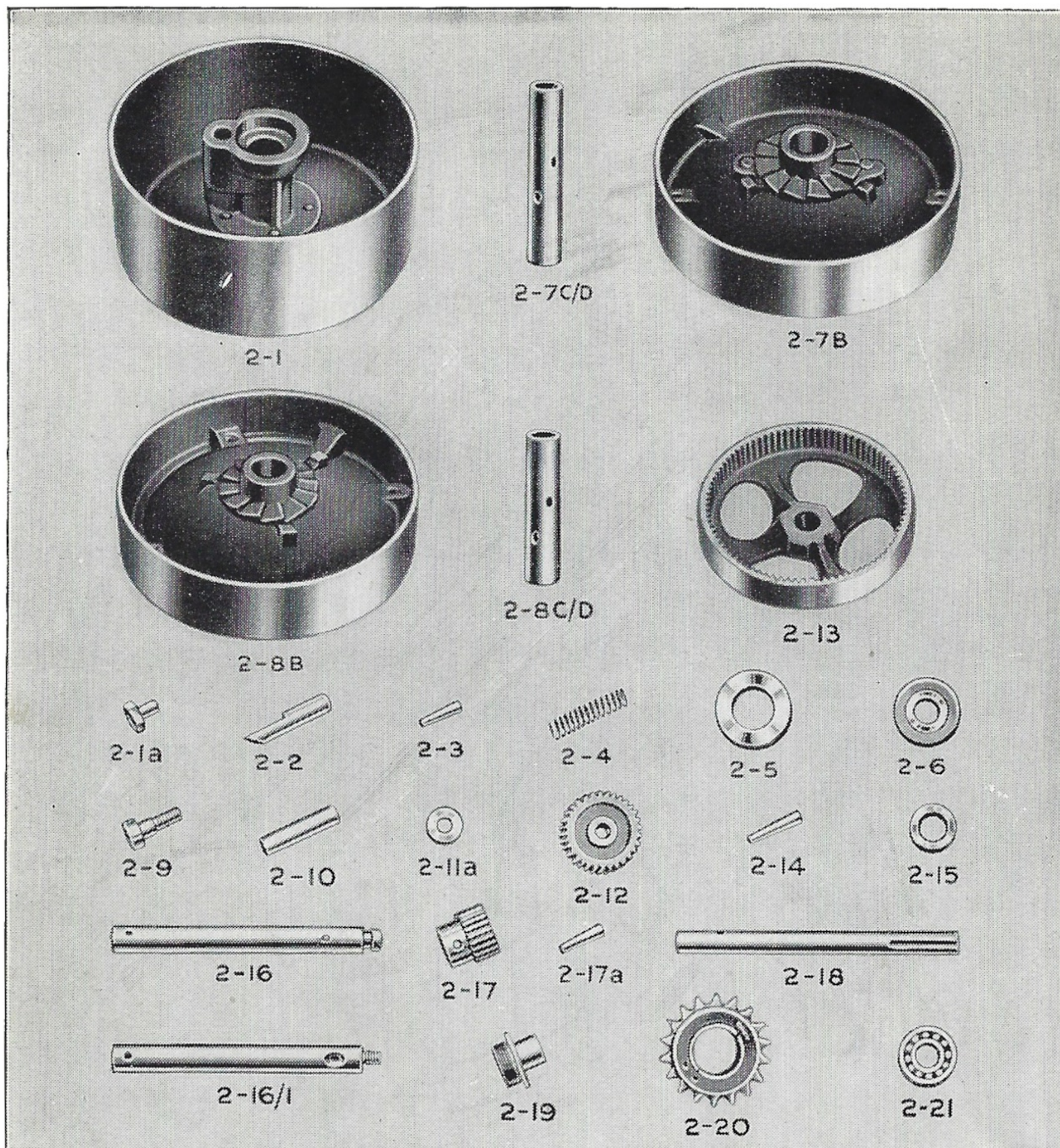

### GROUP 2-0

- |  |  |
|--|--|
| <p>2-1—Outer Drum<br/>                 2-1A—Sealer<br/>                 2-2—Plunger Pawl<br/>                 2-3—Plunger Taper Pin<br/>                 2-4—Plunger Spring<br/>                 2-5—Large Thrust Washer<br/>                 2-6—Medium Thrust Washer<br/>                 2-7B—Planet Half Gear Case<br/>                 2-7C/D—Planet Half Gear Case Tube<br/>                 2-8B—Loose Half Gear Case<br/>                 2-8C/D—Loose Half Gear Case Tube<br/>                 2-9—Gear Case Screws<br/>                 2-10—Planet Gear Axles</p> | <p>2-11—Planet Axle Pin<br/>                 2-11A—Planet Gear Washer<br/>                 2-11B—Split Pin<br/>                 2-12—Planet Gear<br/>                 2-13—Annular Gear<br/>                 2-14—Annular Gear Taper Pin<br/>                 2-15—Annular Gear Washer<br/>                 2-16—Annular Gear Shaft<br/>                 2-16/1—Annular Gear Shaft<br/>                 2-17—Pinion<br/>                 2-17A—Pinion Taper Pin<br/>                 2-18—Pinion Shaft<br/>                 2-19—Free Wheel Sleeve<br/>                 2-20—Free Wheel<br/>                 2-21—Ball Bearing</p> |
|--|--|



## PARTS LIST—continued

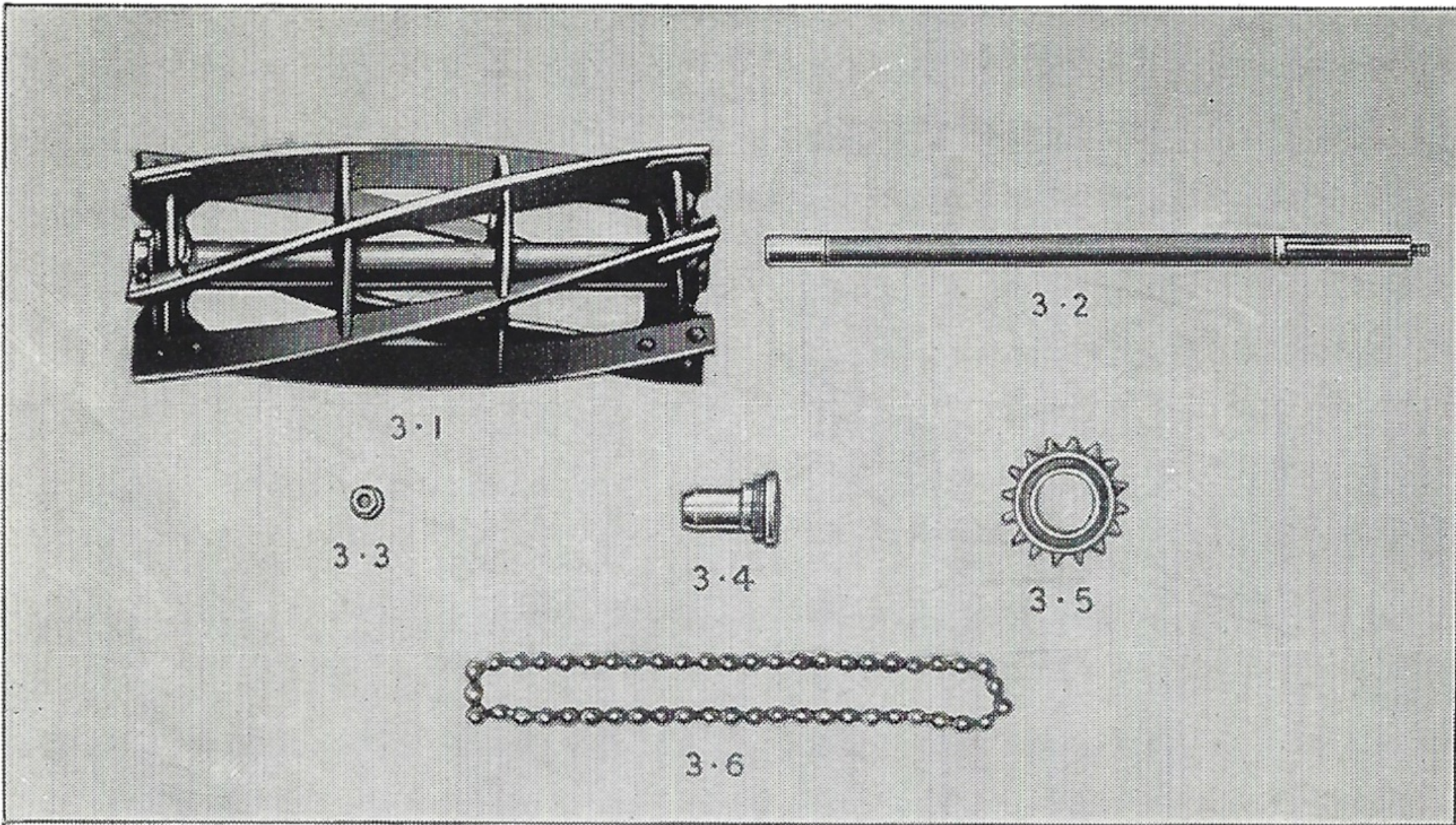

### GROUP 3-0

3-1—Rotary Cutter  
 3-2—Rotary Cutter Shaft  
 3-3—Cutter Shaft Nut

3-4—Sprocket Sleeve  
 3-5—Sprocket Wheel  
 3-6—Chain

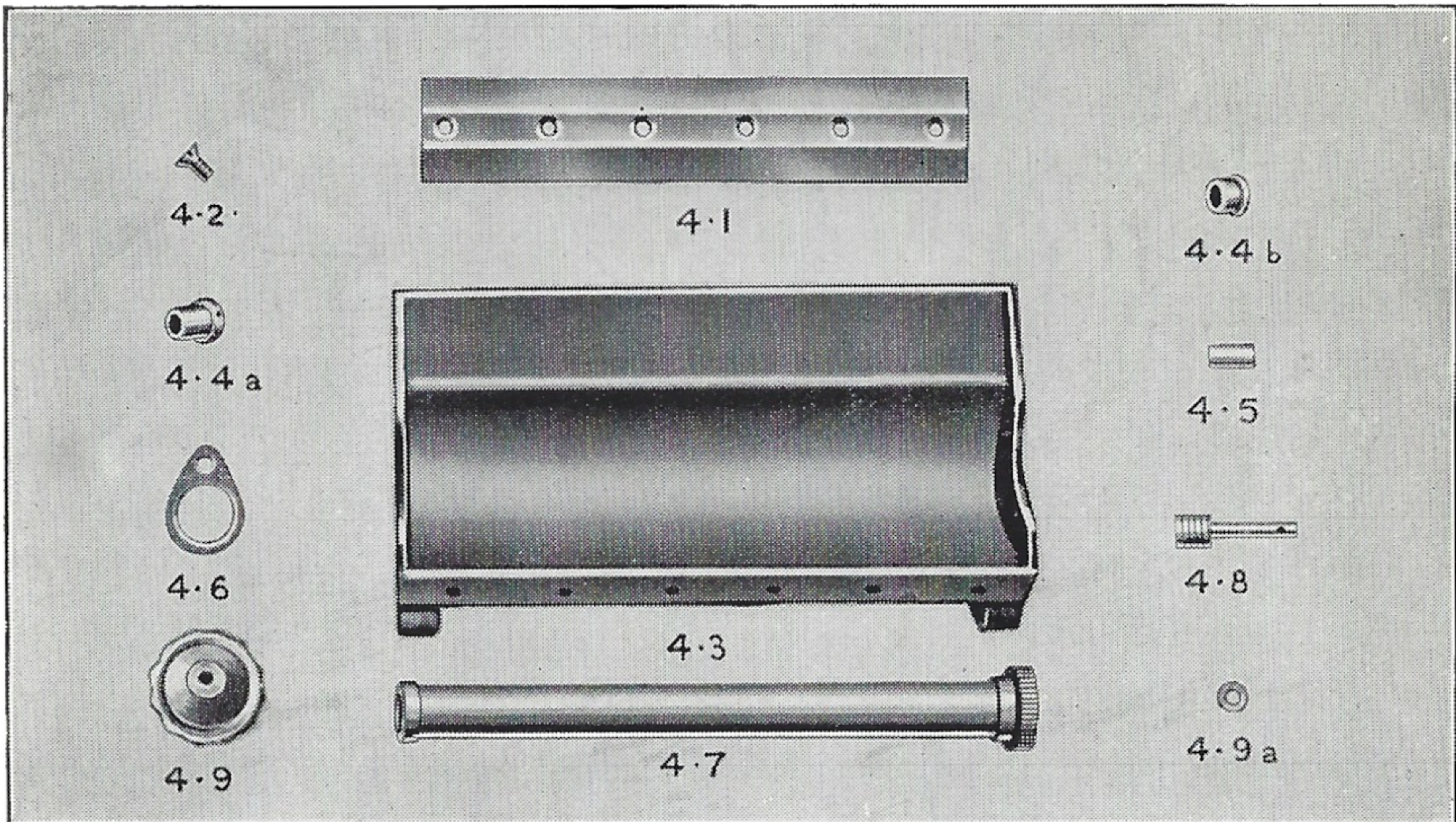

### GROUP 4-0

4-1—Shear Blade  
 4-2—Shear Blade Screw  
 4-3—Shear Blade Frame  
 4-4A—Eccentric Bush  
 4-4B—Plain Bush  
 4-5—Eccentric Strap Pivot

4-6—Eccentric Strap  
 4-7—Shear Blade Adjuster  
 4-8—Adjusting Worm  
 4-9—Hand Wheel  
 4-9A—Spring Washer  
 4-10—Taper Pin



## PARTS LIST—continued

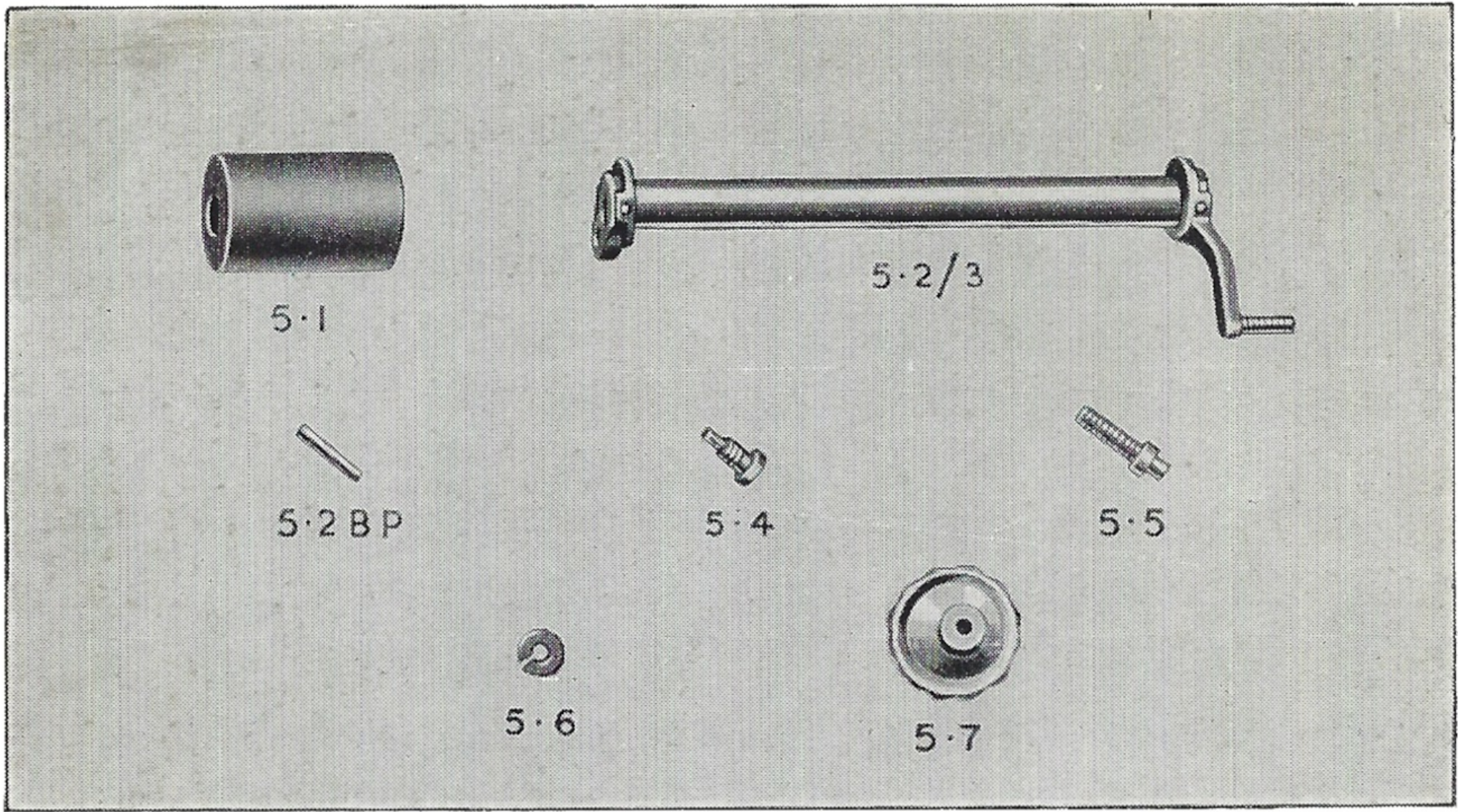

### GROUP 5-0

5-1—Hardwood Roller  
 5-2/3—Front Axle  
 5-2BP—Taper Pin  
 5-4—Front Axle Pivot Screw

5-5—Stud for Roller Adjusting Arm  
 5-6—Washer for Roller Adjusting Arm  
 5-7—Screwed Hand Wheel

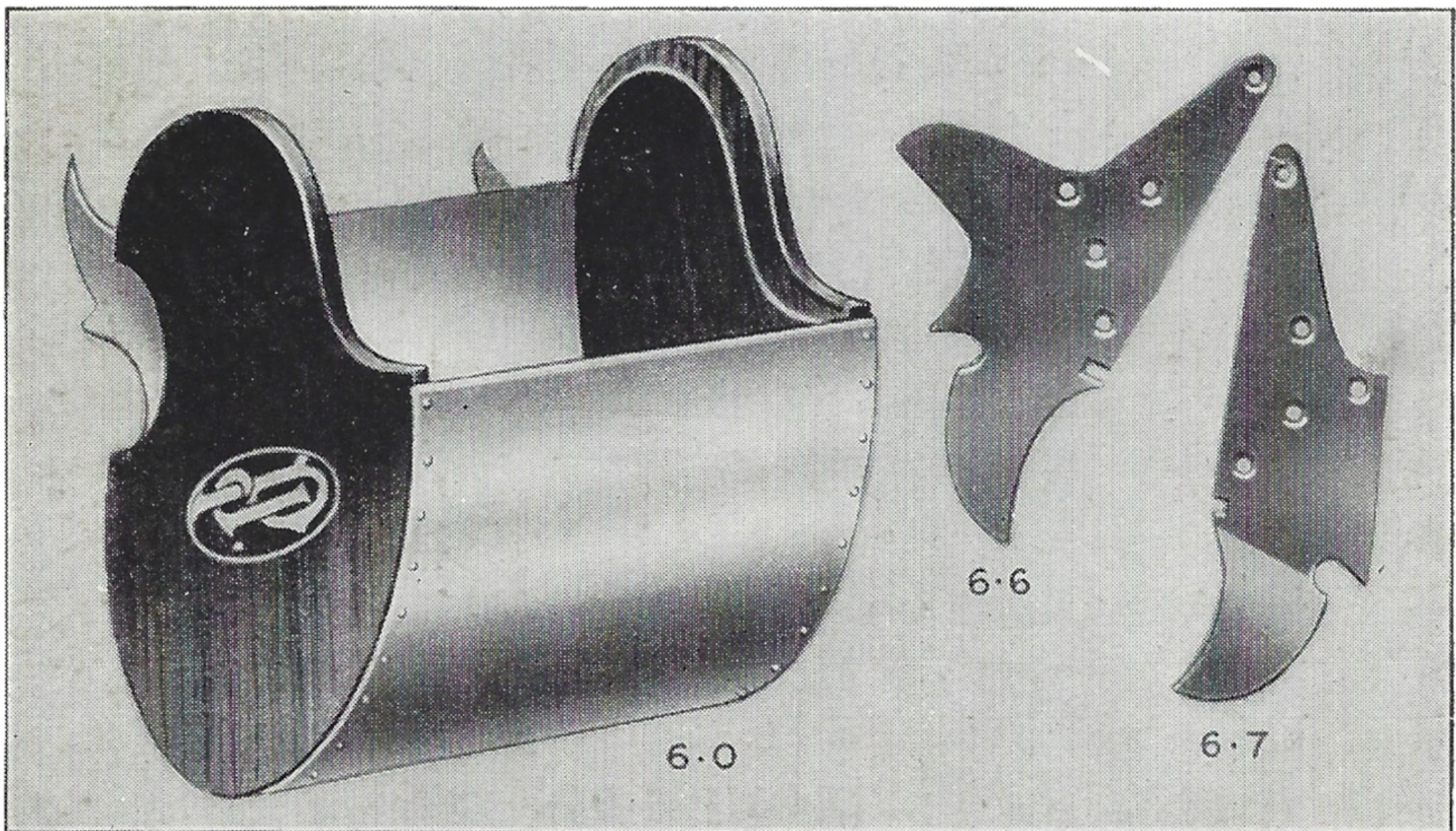

### GROUP 6-0

6-0—Grass Box  
 6-6—Large Wing for Grass Box

6-7—Small Wing for Grass Box







